

2025 Fourth Quarter Earnings Conference

March 2026

Safe Harbor Notice

- Psi's statements of its current expectations are forward-looking statements subject to significant risks and uncertainties and actual results may differ materially from those contained in the forward-looking statements.
- Information as to those factors that could cause actual results to vary can be found in PSI's Annual or Quarterly Report filed with Taiwan Stock Exchange Corporation (TWSE) and such other documents as PSI may file with, or submit to the TWSE from time to time.
- Except as required by law, we undertake no obligation to update any forward-looking statement, whether as a result of new information, future events, or otherwise.
- The numbers of the presentation are prepared under IFRS.

Agenda

- Financial Performance
- Semi Industry Outlook
- Drivers of Business Expansion
- Long-Term Competitive Moat
- Key Messages

Financial Performance

Financial Highlights

2025Q4		
Revenue	GPM	OPM
NT\$ 1,219M	33.4%	21.5%

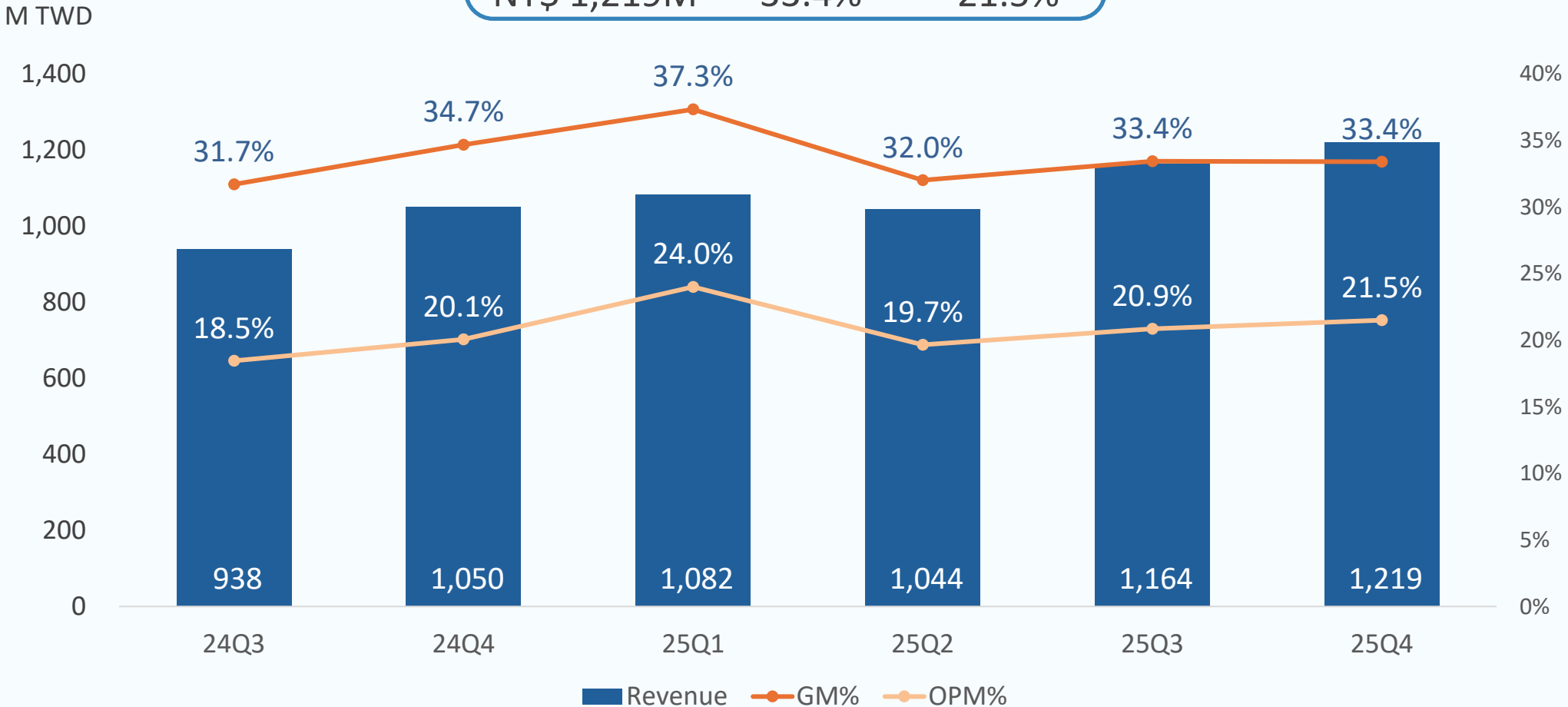

Financial Matrix

Item	2024Q4	2025Q3	2025Q4	Y2024	Y2025
Shipment (Kpcs, 12"-equiv. Wafer)	1,963	2,531	2,599	6,869	9,486
Net Revenue (US\$ Millions)	32	38	39	110	144
Net Revenue (NT\$ Millions)	1,050	1,164	1,219	3,551	4,509
Gross Margin	34.7%	33.4%	33.4%	28.8%	34.0%
Operating Margin	20.1%	20.9%	21.5%	15.1%	21.5%
Net Profit Margin	19.0%	17.3%	18.4%	15.7%	16.8%
EPS (NT\$)	1.16	1.17	1.29	2.85	4.37
ROE (annualized)	19.9%	17.8%	18.3%	12.2%	16.4%
Operating Cash Flow (NT\$ M)	449	261	410	1,491	1,401
Capital Expenditures (NT\$ M)	549	-313	-1,135	-1,364	-3,180
Free Cash Flow (NT\$ M)	-100	-52	-723	126	-1,779

Semi Industry Outlook

AI-Driven Chips to Top \$1 Trillion

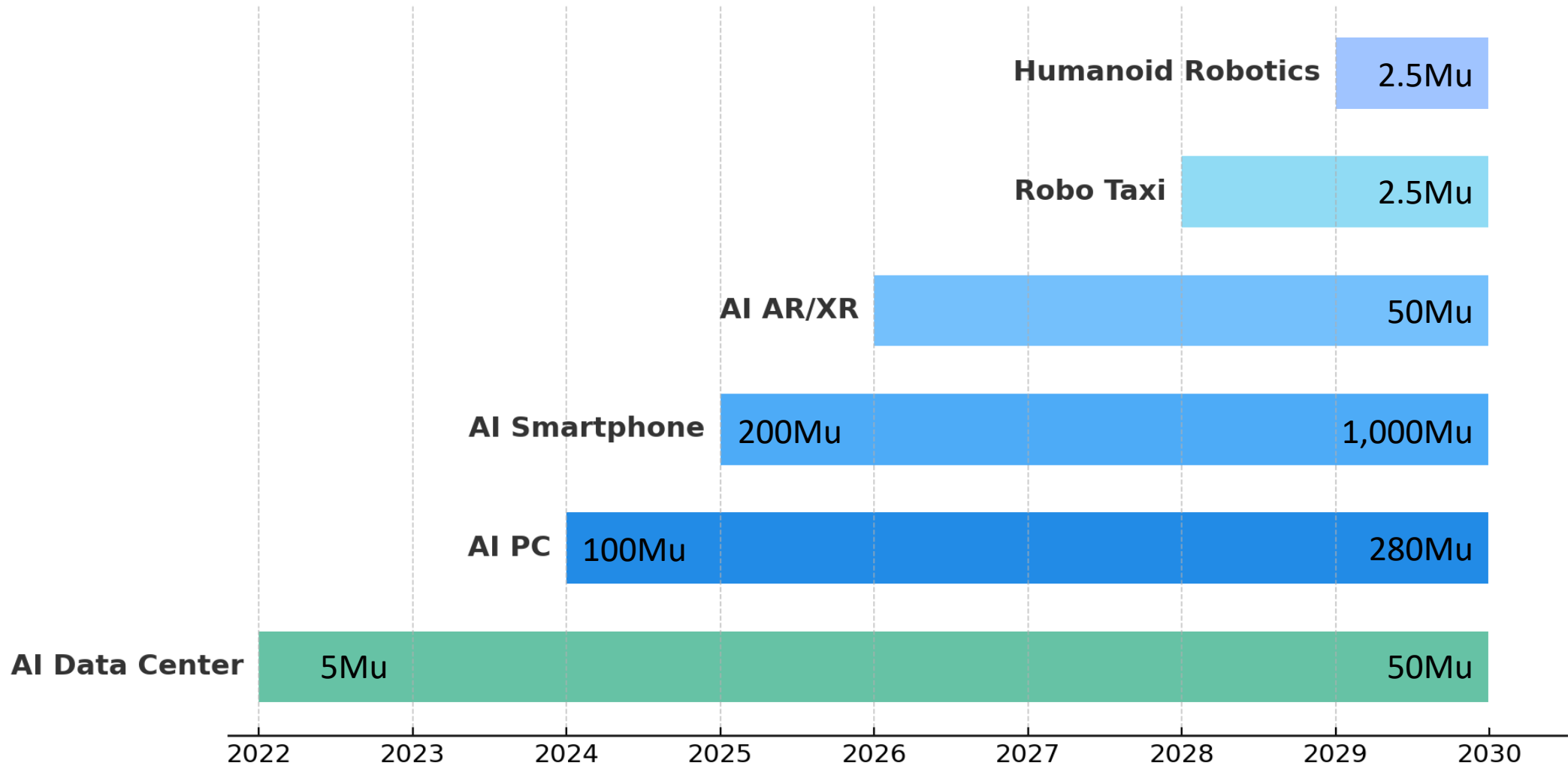

Source: WSTS, IDC, TSMC



Top 5 CSPs CapEx Revving Up

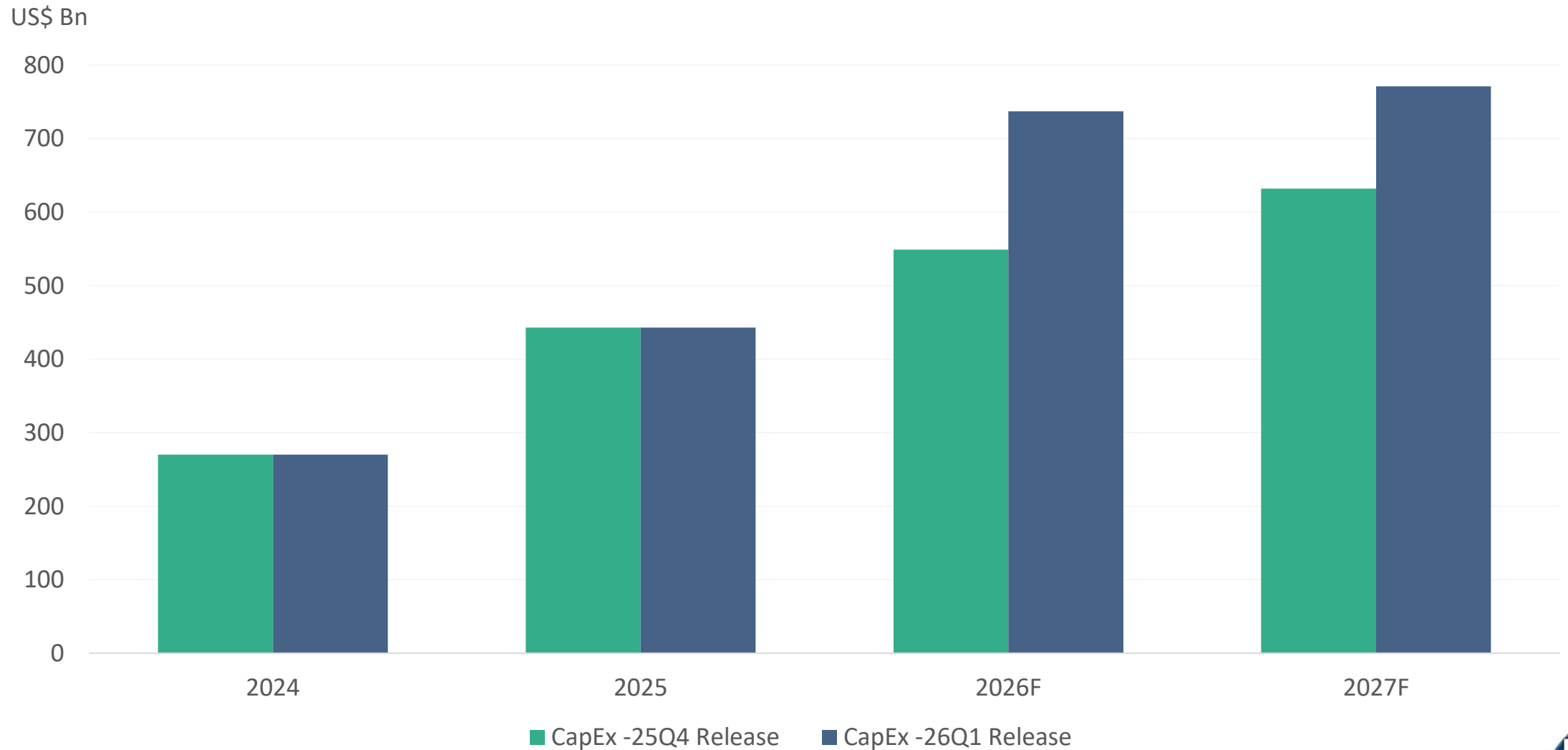

Source: UBS, GS



Drivers of Business Expansion

Reclaim: Scaling with Advanced Technology

Sub 2nm Capacity Scaling UP

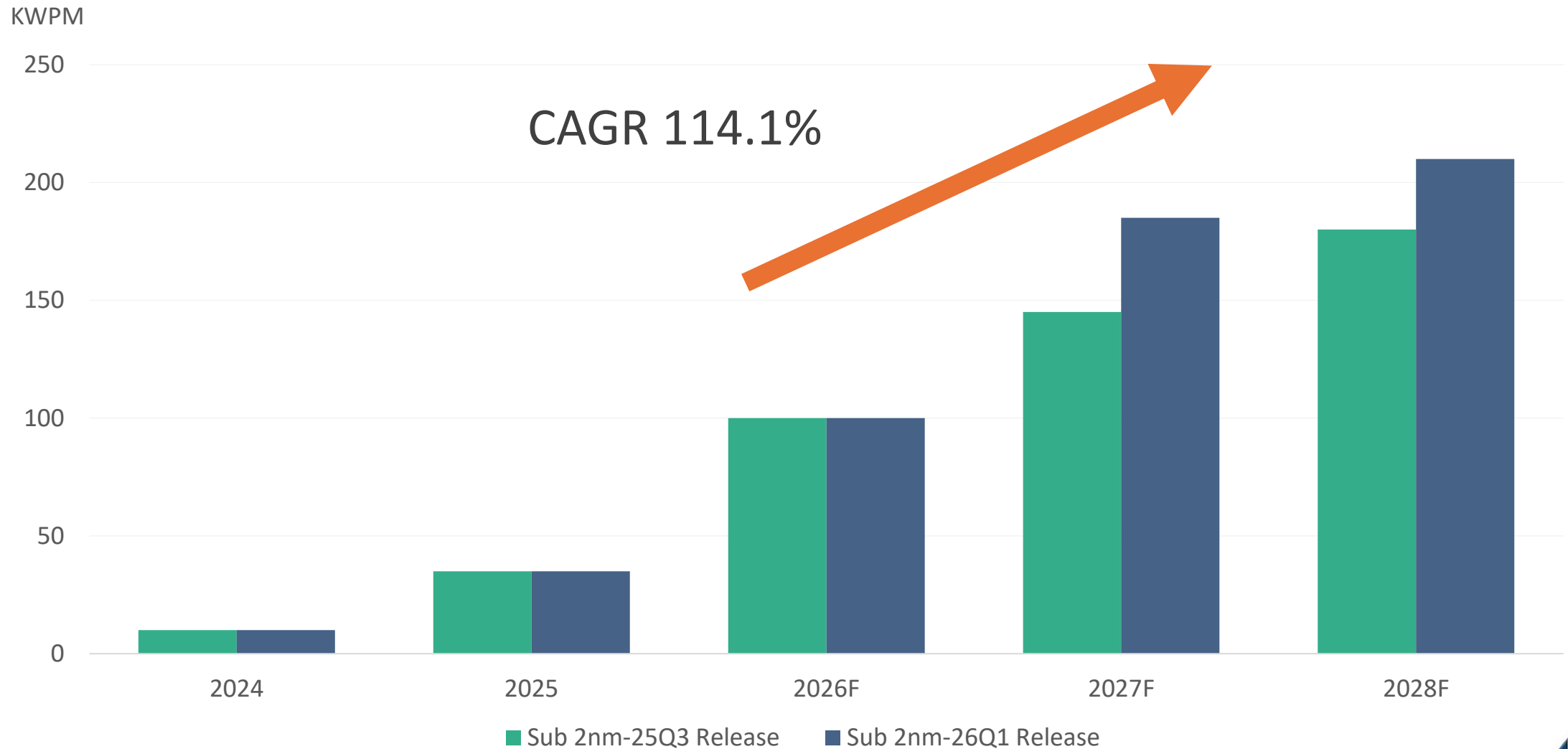

Source: JPM, UBS ,GS



Advanced Packaging Ramping Up

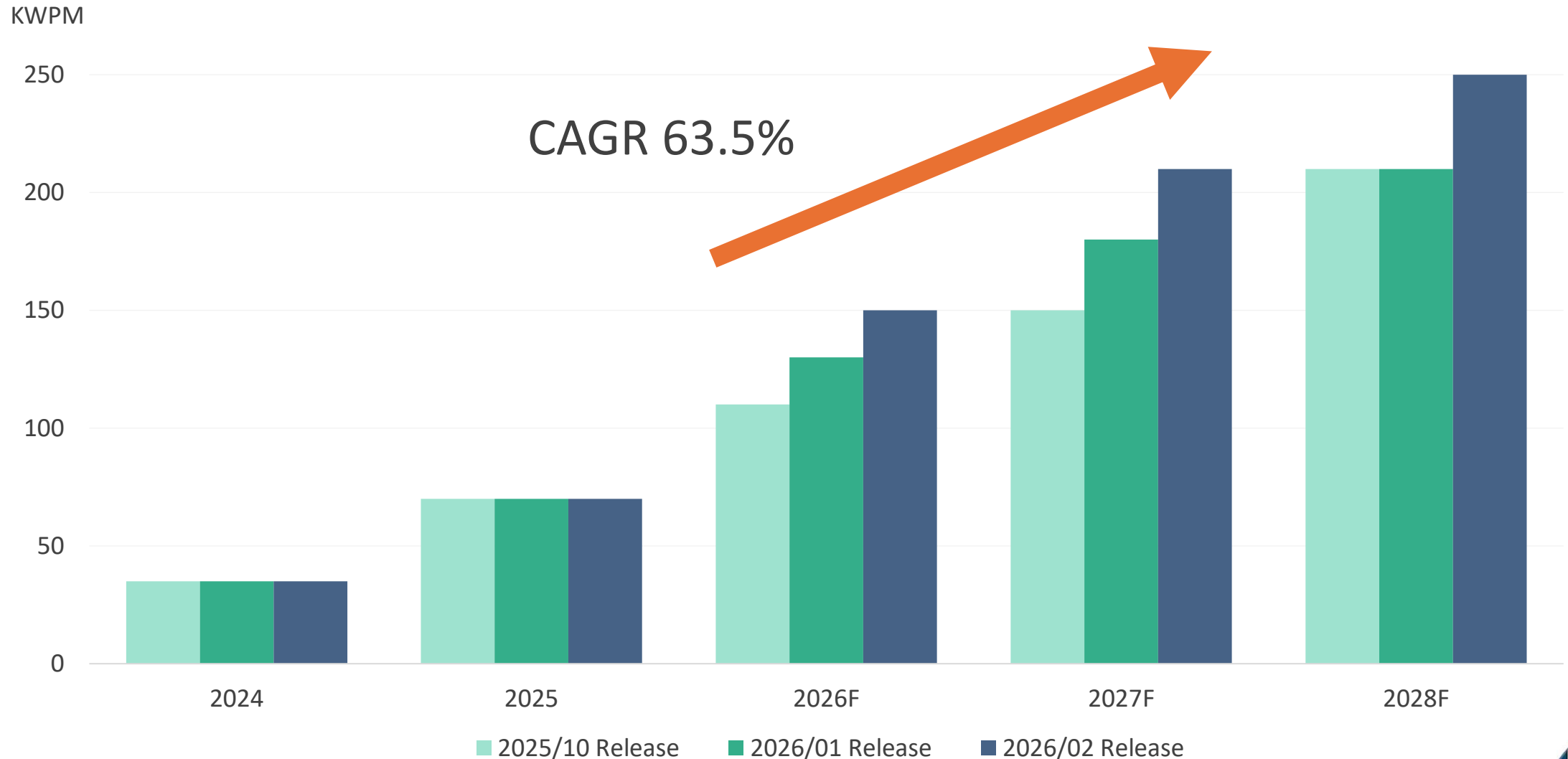

Source: JPM, UBS ,GS



Memory Wafer Starts

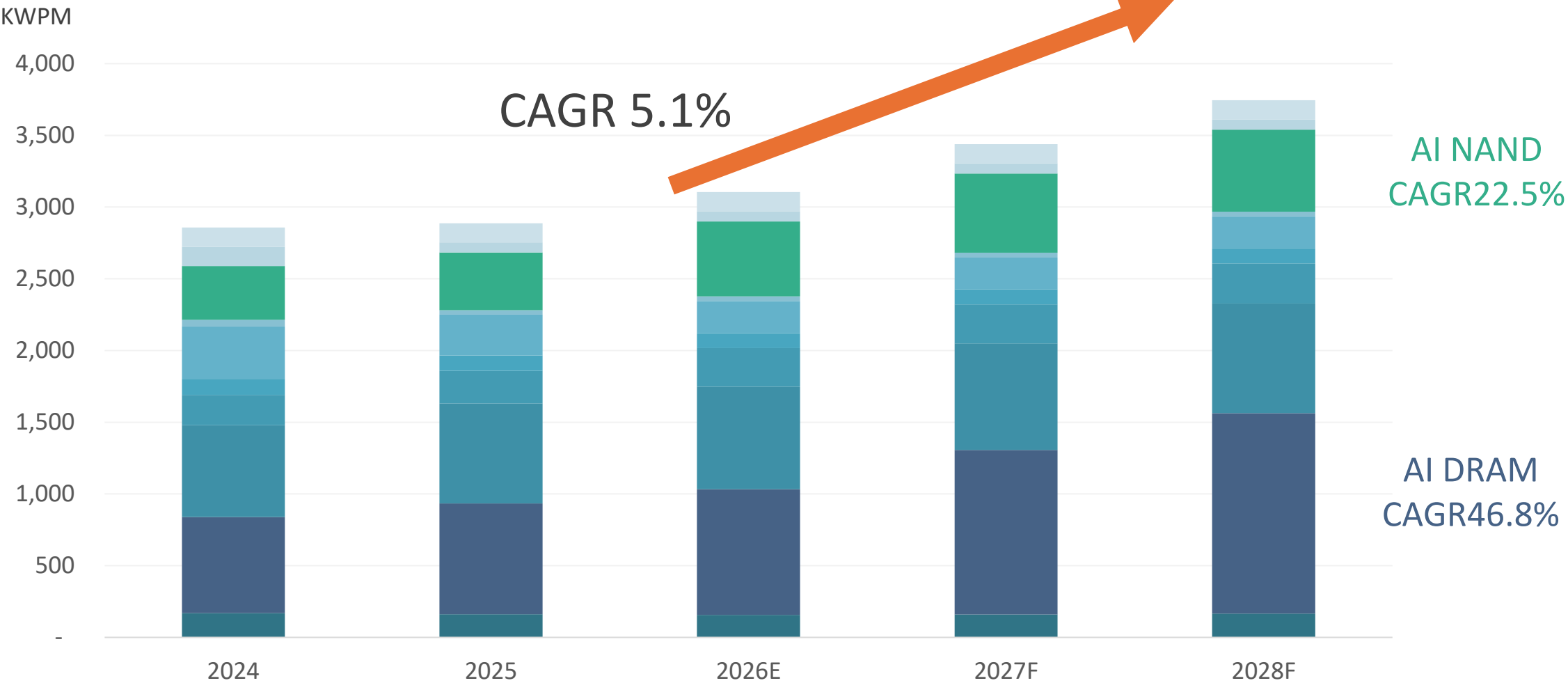

Source: TF, Sumco

- DRAM PC
- DRAM Server
- DRAM Mobile
- DRAM Graphics
- DRAM Consumer
- NAND PC
- NAND Graphics
- NAND Server
- NAND Consumer
- NAND Others



Process Complexity Driving Reclaim Demand

- Structural Transition & Design Challenges
- Manufacturing Precision & Yield Pressure

FinFET

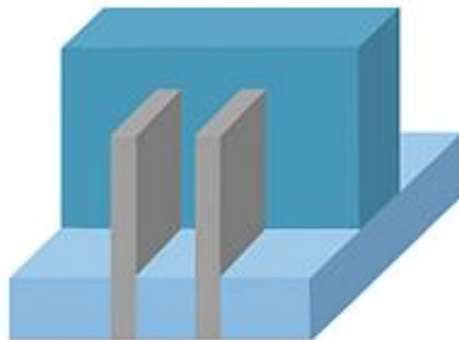

Nanosheet

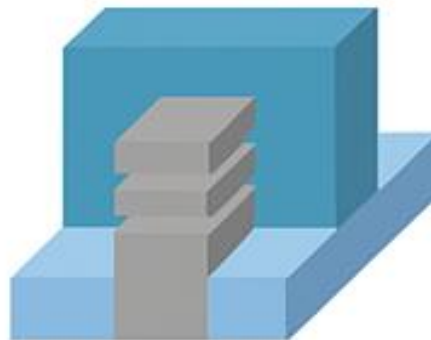

Forksheets

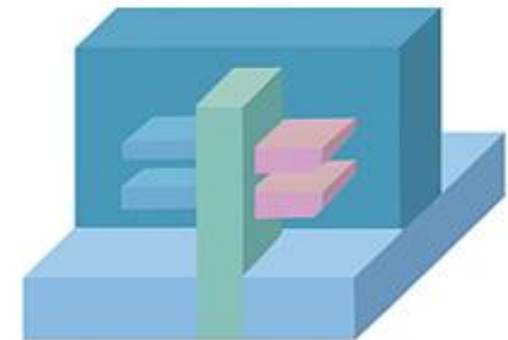

Node Evolution & Reclaim Demand

Reclaim Usage Ratio

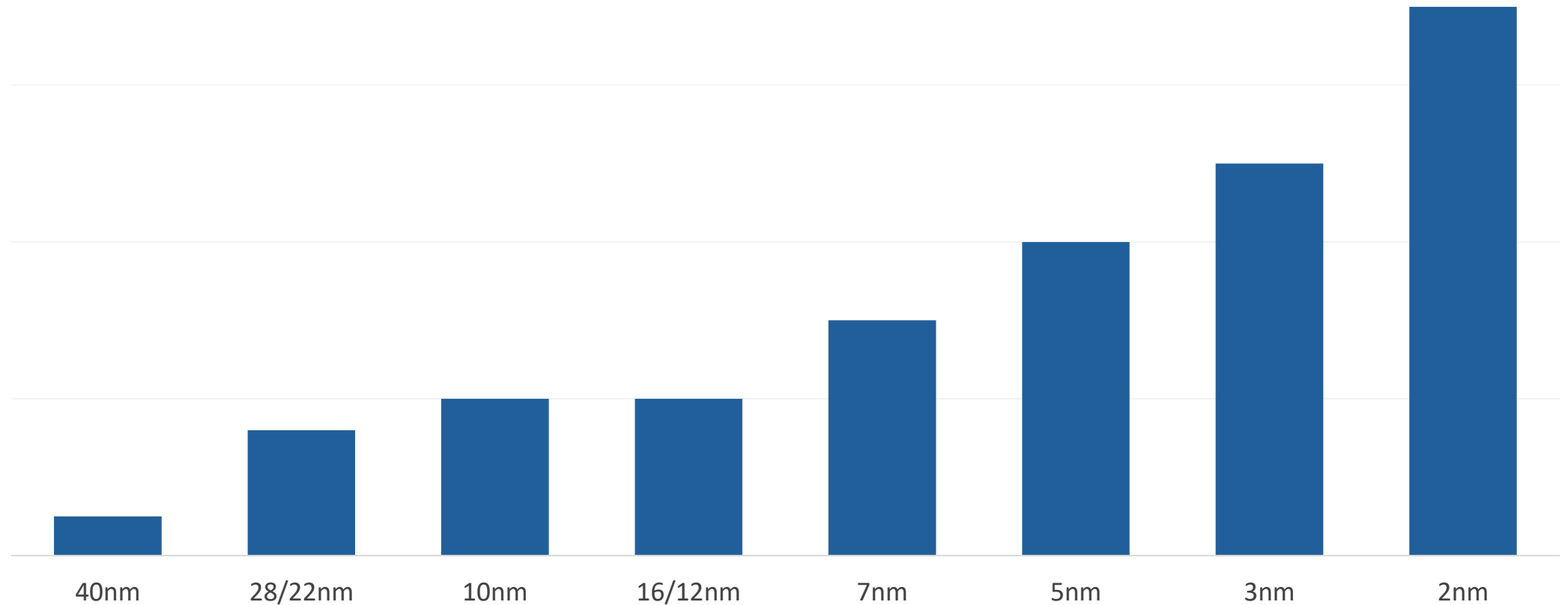

Source: PSI estimate



Accelerating Market Share Gains

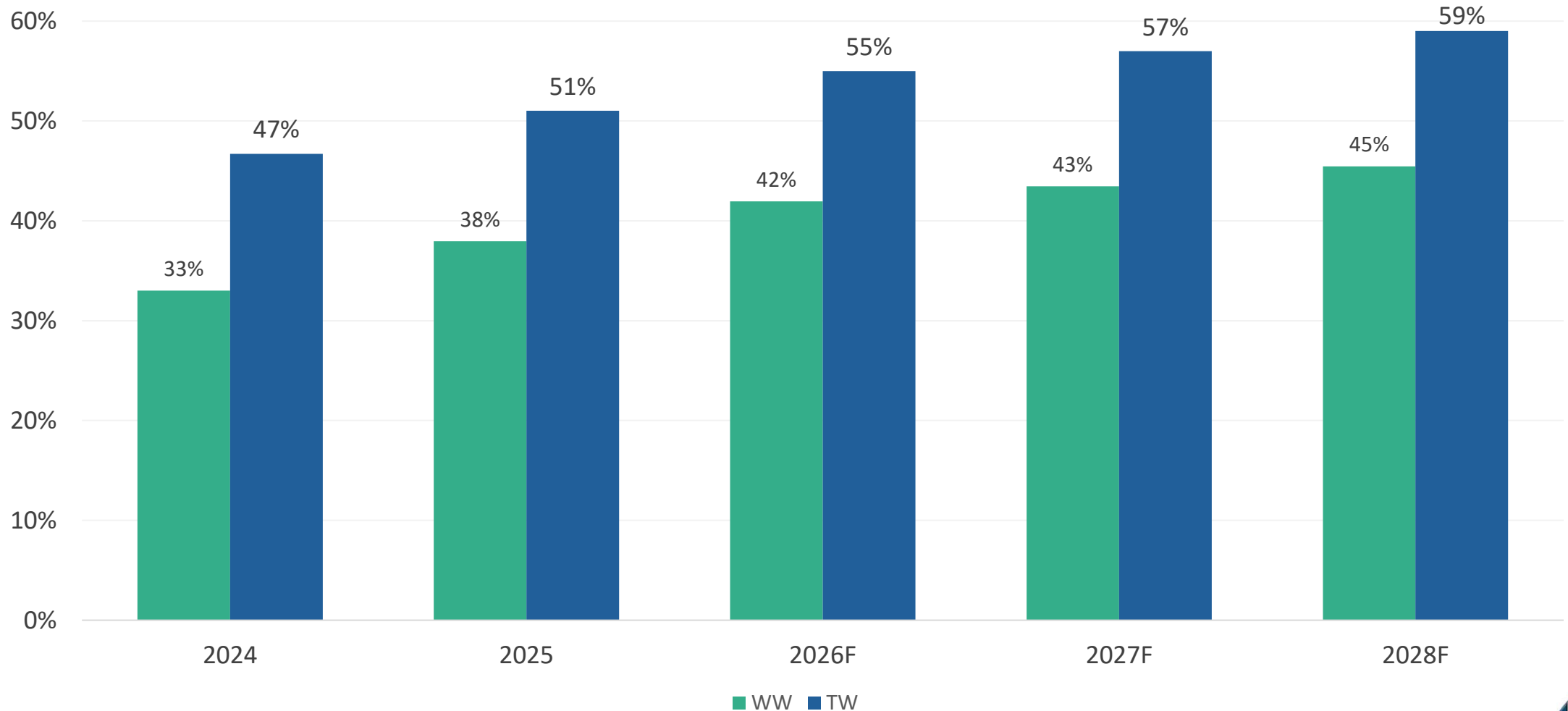

Source: company data, PSI



Drivers of Business Expansion

Thinning : Potential Drivers from 12" Si and SiC

Dr. MOS Capturing Multi-market Growth

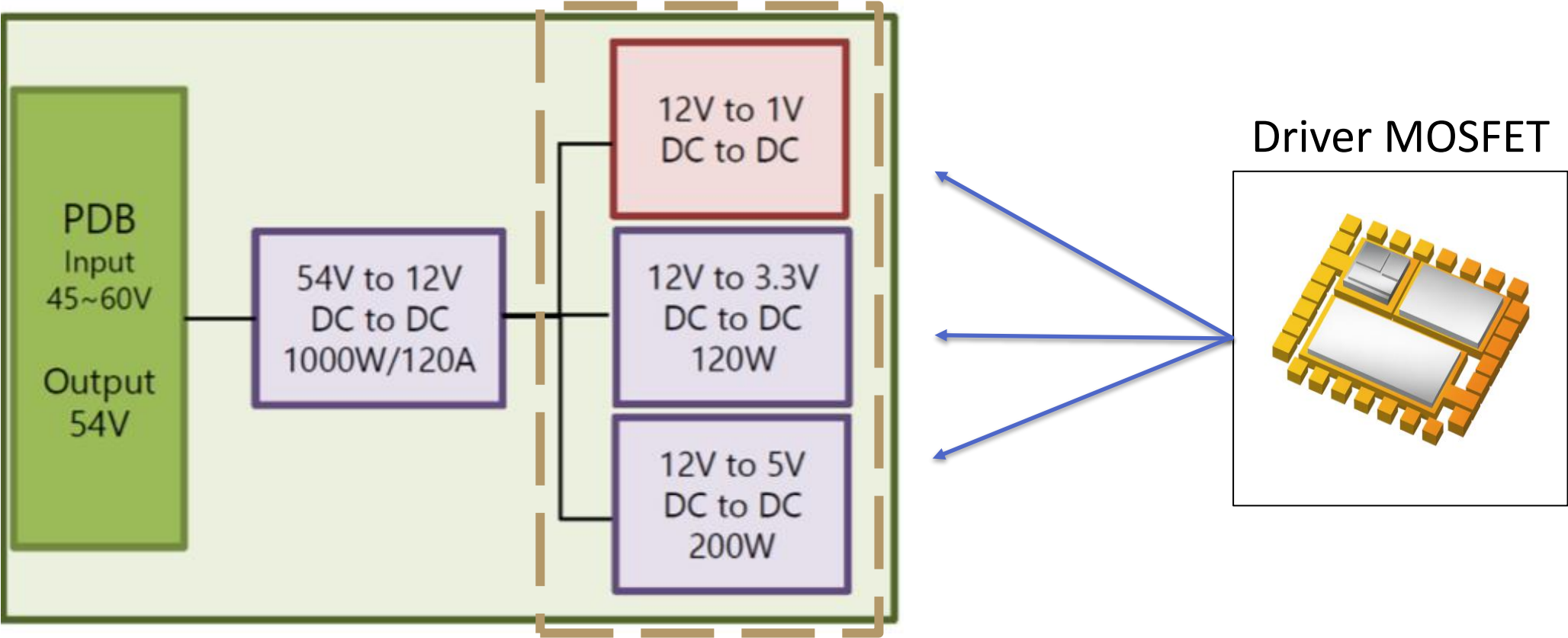

Scaling Up 12-inch Si Thinning for Next-Gen

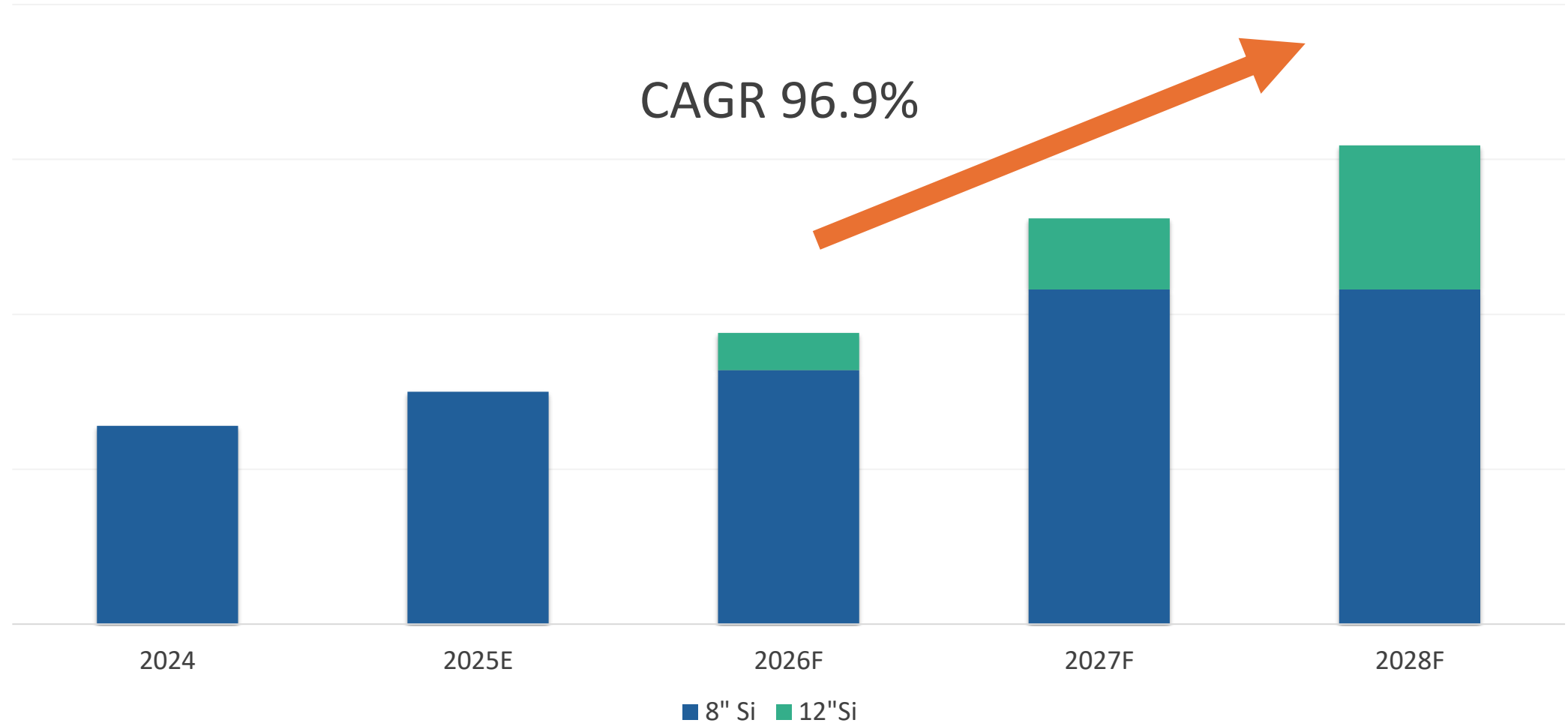

Source: PSI estimate



Beyond Silicon - Silicon Carbide Key Properties

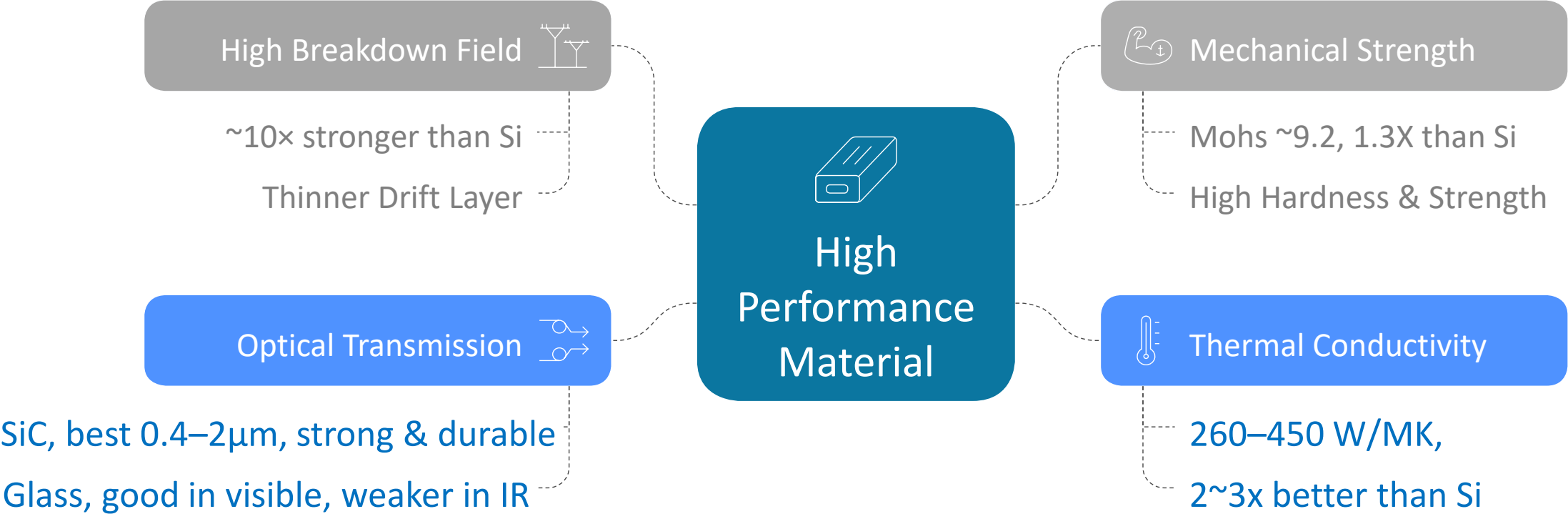

Source: company data, PSI



SiC New Era – Blooming Applications

Heat Dissipater

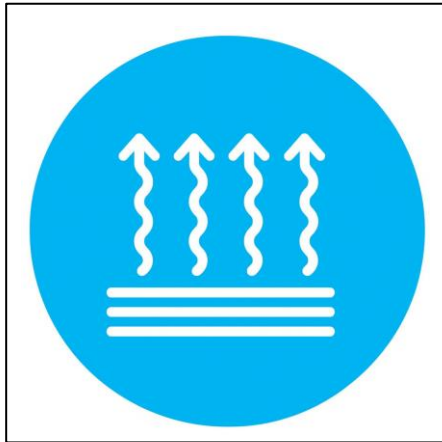

IC Substrate

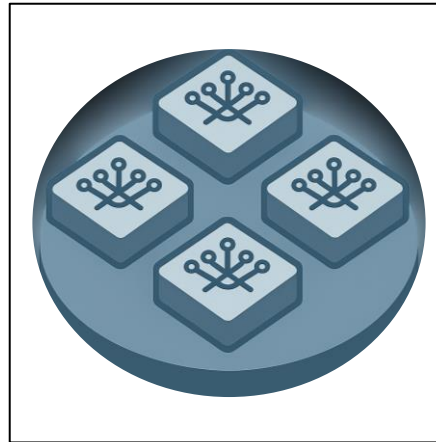

Specialty glass

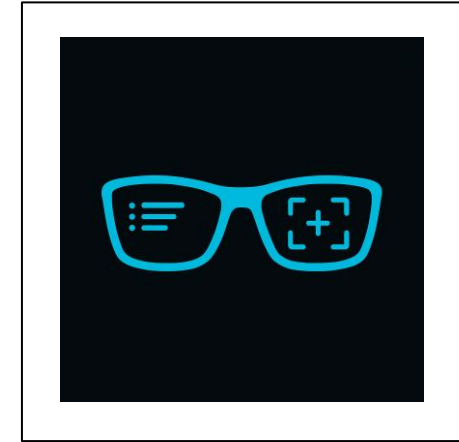

Long-Term Competitive Moat

PSI's Competitive Moat

TECHNOLOGY

- OHT compatible dry in dry out polishing
- Near prime single wafer cleaning



EFFICIENCY

- Streamline flow via Automation and AI
- Double per capita outcomes in three years

Scalability

- Worldwide leading capacity build up
- Top tier long term supply chain relationship

S.E.T. The Growth Energies

Turning Scalability, Efficiency and Technology into the Sustainable Profit.

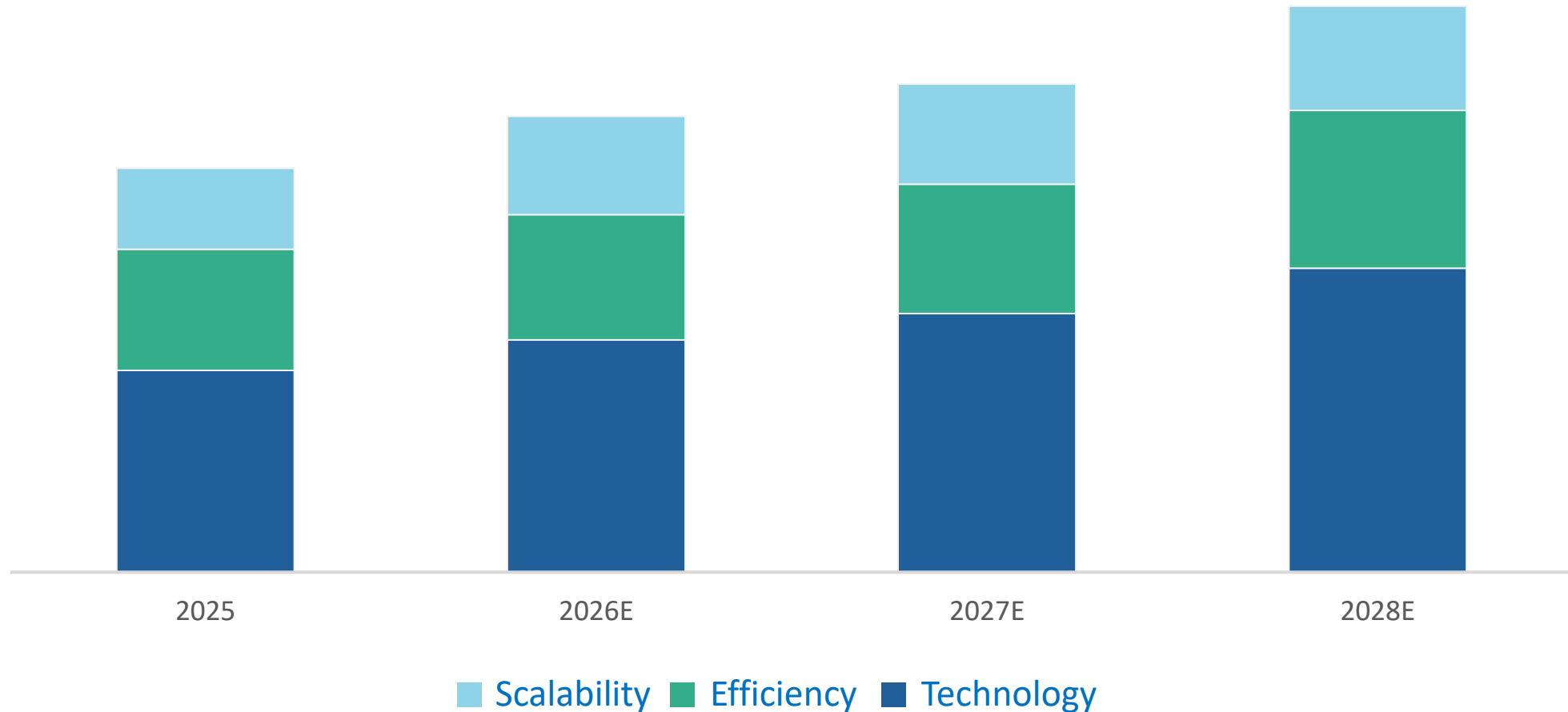

Key Takeaways

Key Takeaways

- **PSI's Moat, Technology, Efficiency, Scalability**
- **Riding the AI Wave:** Critical Demand for Advanced Nodes & Packaging
- **Operational Excellence:** Driving Profitability via AI Automation
- **Unlocking the 2nd Growth Curve:** SiC Wafering Technology
- **Strategic Expansion:** Building Capacity for the Next Decade

<https://www.psi.com.tw>

ir@psi.com.tw
